

X-SNAPPER XL SERIES

X-Snapper range

The Nexmosphere X-Snapper range offers magnetic pick-up sensors that can also be used as active security devices. Merchandise is mounted onto the sensor and when lifted or placed back, the X-Snapper sends a trigger to the connected Xperience controller, facilitating content triggering and measurement of pick-up durations. The security function sends triggers whenever merchandise is removed, the wire is cut or pulled out. This sensor is specially designed to attach to hand-held devices of different sizes and shapes.

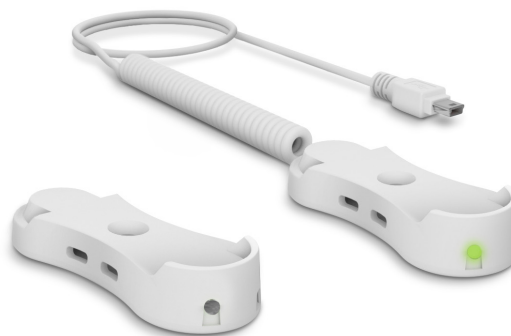

XL series

The XL-Snapper detects either release from, or connection with, -its passive counter block and sends triggers to the connected Xperience controller accordingly, both registering pick-ups and place downs. Use the flat XL-Snapper for presenting larger devices like tablets and the curved model for rounded devices such as hair stylers.

Features

- Magnetic pick-up detection sensor
- Active product security
- Auto-calibration

X-talk

The XL-Snapper can easily be connected to any of the Nexmosphere Xperience controllers using the X-talk interface. All settings of the sensor are programmable on the controller, enabling a seamless integration in your application.

- Plug and smile interface
- Compatible with any Nexmosphere Xperience controller
- Powered by and configurable with Nexmosphere Xperience controller

Pickup detection

The sensor registers release from, or connection with, -its passive counter block. Both events will be sent as triggers from the Xperience controller to the connected media player, for example, to start a video or illuminate a string of LEDs.

- Pick-up and place-down registration
- Highly responsive

Security

The alarm gets triggered if the merchandise is removed; cables are cut or removed from the Xperience controller. The micro-optical sensor has no moving parts eliminating false alarms caused by commonly used micro-switches.

- No mechanical moving parts that break by intense use
- Easy to setup and maintain (plug and secure)
- Status LED clearly indicates alarm status (programmable/dimmable on Xperience controller)

Benefits

- 4 strong neodymium magnets ensure that the product always returns to its original position
- Securely mounts on any flat surface, horizontal, vertical, or angled
- Light and flexible cable allows customers to experience the real weight and feel of the merchandise
- Easy removable non-marking double-sided tape
- Status LED for visual feedback
- Available with flat or curved cover

X-SNAPPER XL SERIES

Mounting specifications

Adhere the sensor to the merchandise using the double-sided adhesive tape on the flat bottom side.

Thermal specifications

Operating temperature: +10°C...+40°C/ +50°F ... +104°F
Storage temperature: -20°C...+50°C/ -4°F ... +122°F

Electrical specifications

- Operating voltage: 5V DC (via X-talk interface)
- Power consumption: 50mA

Miscellaneous

- Custom cable lengths available on request (MOQ 50pcs)
- 1-year warranty (optional 3-year extended warranty available)

Packaging

Items per carton 1, 10 or 50 pcs

Standards and Certifications

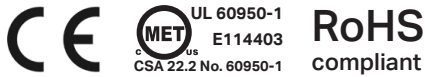

Mechanical dimensions

flat cover:

LxWxH: 69 x 27 x 13,7 mm
Screw fixation: Double-sided adhesive tape

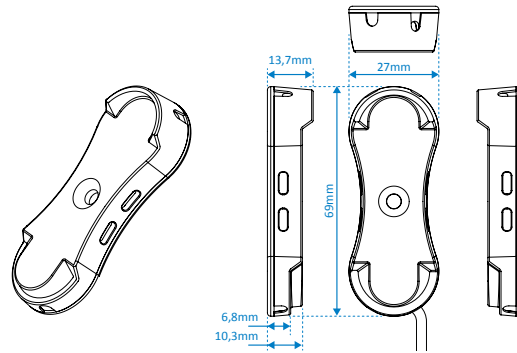

curved cover:

LxWxH: 69 x 27 x 16 mm
Screw fixation: Double-sided adhesive tape

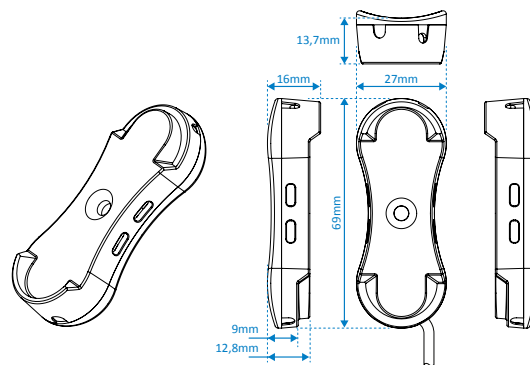

Ordering information

Product ID	Description	Netto weight	Quantity
XLFW-X16	XL-Snapper, Pick-up only, flat cover, 180cm cable, white	52g	1 pc
XLFW-X26	XL-Snapper, Security only, flat cover, 180cm cable, white	52g	1 pc
XLFW-X36	XL-Snapper, Pick-up & Security, flat cover, 180cm cable, white	52g	1 pc
XLFW-NOS	XL-Snapper single, flat cover, standard strength, white	20g	1 pc
XLCW-X16	XL-Snapper, Pick-up only, curved cover, 180cm cable, white	52g	1 pc
XLCW-X26	XL-Snapper, Security only, curved cover, 180cm cable, white	52g	1 pc
XLCW-X36	XL-Snapper, Pick-up & Security, curved cover, 180cm cable, white	52g	1 pc
XLCW-NOS	XL-Snapper single, curved cover, standard strength, white	20g	1 pc
XLFB-X16	XL-Snapper, Pick-up only, flat cover, 180cm cable, black	52g	1 pc
XLFB-X26	XL-Snapper, Security only, flat cover, 180cm cable, black	52g	1 pc
XLFB-X36	XL-Snapper, Pick-up & Security, flat cover, 180cm cable, black	52g	1 pc
XLFB-NOS	XL-Snapper single, flat cover, standard strength, black	20g	1 pc
XLCB-X16	XL-Snapper, Pick-up only, curved cover, 180cm cable, black	52g	1 pc
XLCB-X26	XL-Snapper, Security only, curved cover, 180cm cable, black	52g	1 pc
XLCB-X36	XL-Snapper, Pick-up & Security, curved cover, 180cm cable, black	52g	1 pc
XLCB-NOS	XL-Snapper single, curved cover, standard strength, black	20g	1 pc

Nexmosphere

High Tech Campus 10 (Mμ building)
5656 AE Eindhoven • The Netherlands

T +31 40 240 7070
E sales@nexmosphere.com

© 2017-2020 Nexmosphere. All rights reserved. v1.0 / 02-20
All content contained herein is subject to change without prior notice.